

Flange type of nozzle flowmeter ZPK

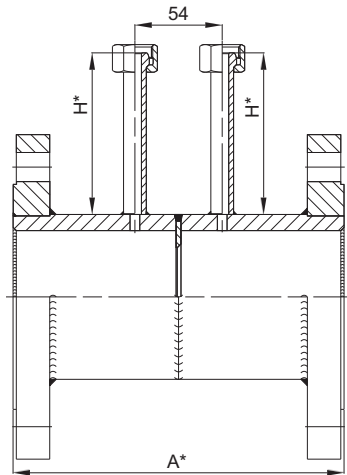

Technical data:

- nominal pressure PN6+PN100
- size of flowmeter DN25+DN800
- material of flow element (orifice, nozzle):
stainless steel 1.4301
- material of construction elements:
carbon steel
austenitic steel
stainless steel
- temperature up to 500°C
- material certification
- calculation acc. to PN-EN ISO 5167, ISO/TR 15377

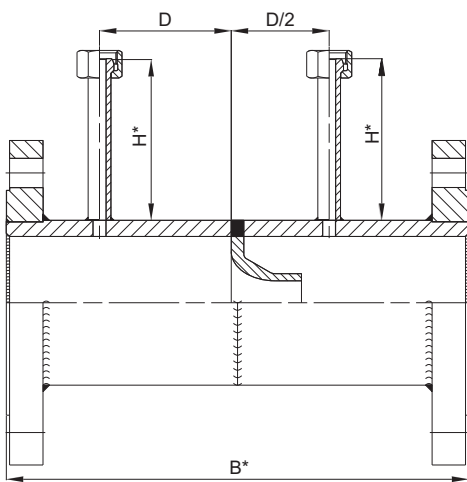

Application:

Nozzle flowmeter is used for flow measurement of liquid medium in close pipeline.
An orifice plate installed in line creates a pressure drop. This difference of pressure is measured via impulse line by differential pressure transmitter. The relationship between the rate of flow and pressure drop is very well known and allows to easily convert measured pressure difference to flow value.
Flowmeters without correction are used for mediums with constant values of pressure and temperature.
For custody transfer measurement it's recommend to use differential pressure transmitters without SQRT characteristic and correction from changes of medium's pressure and temperature. This kind of measurement have to be calculated in dedicated flow counters.
Characteristic:
- high accuracy of measurement in wide range of flow
- resistant for aggressive media
- work in wide range of temp. and pressure

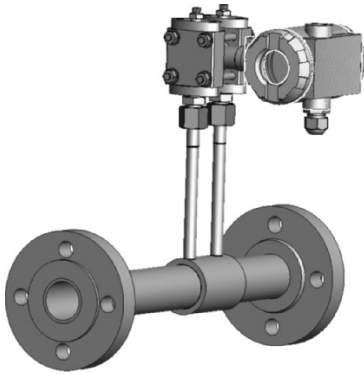

DN	25	32	40	50	65	80	100	125	150	200	250	300	350	400	500	600	800
A	150		200			250		300	350	400	500		600			800	
B	150	165	185	210	245	285	330	390	450	570	700	820	940	1060	1300	1550	2040
H	60	70	80	90	90	90	95	110	115	105	115	130	145	150	180	180	200

Version with straight sections and flanges for screwing

Ordering procedure:

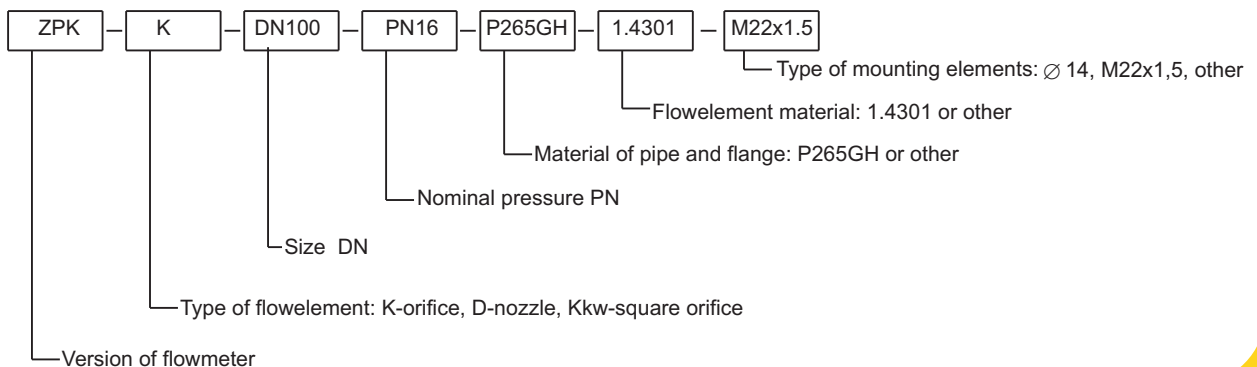

Welded type of nozzle flowmeter ZPK

NEW

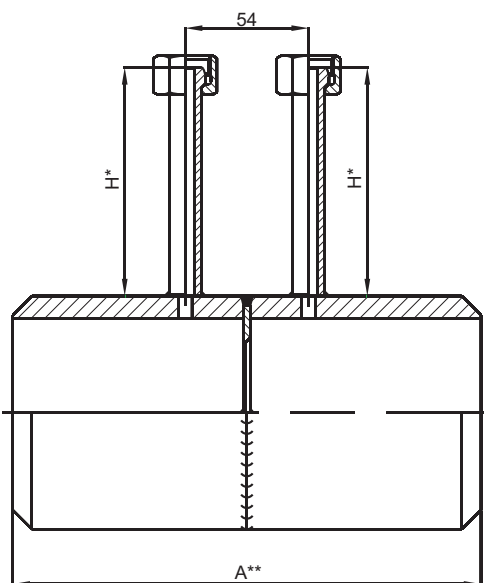

Technical data:

- nominal pressure PN6+PN100
- size of flowmeter DN25÷DN800
- material of flow element (orifice, nozzle): stainless steel 1.4301
- material of construction elements: carbon steel, austenic steel, stainless steel
- temperature up to 500°C
- material certification
- calculation acc. to PN-EN ISO 5167, ISO/TR 15377

Application:

Nozzle flowmeter is used for flow measurement of liquid medium in close pipeline.

An orifice plate installed in line creates a pressure drop. This difference of pressure is measured via impulse line by differential pressure transmitter. The relationship between the rate of flow and pressure drop is very well known and allows to easily convert measured pressure difference to flow value.

Flowmeters without correction are used for mediums with constant values of pressure and temperature.

For custody transfer measurement it's recommend to use differential pressure transmitters without SQRT characteristic and correction from changes of medium's pressure and temperature. This kind of measurement have to be calculated in dedicated flow counters.

Characteristic:

- high accuracy of measurement in wide range of flow
- resistant for aggressive media
- work in wide range of temp. and pressure

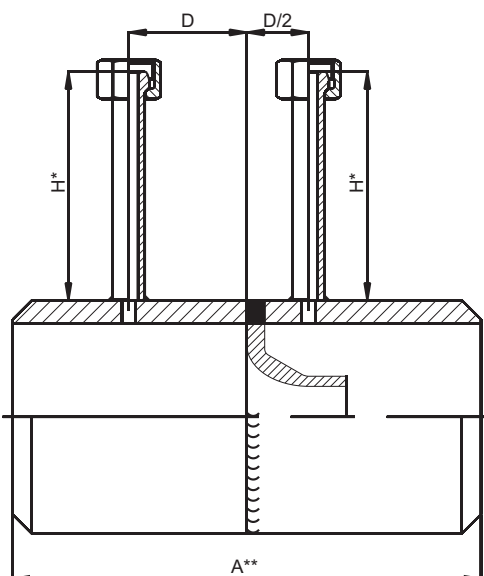

Ordering procedure:

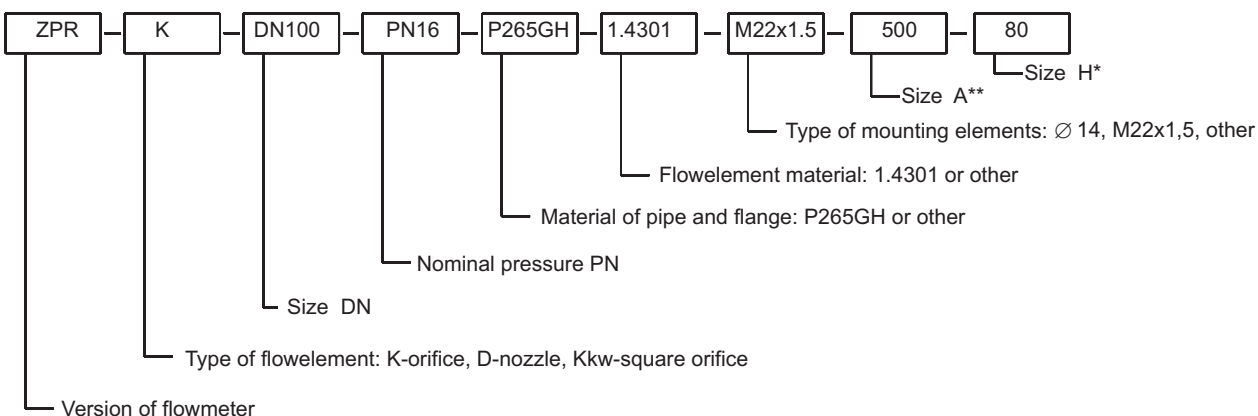

Orifice flowmeter with assembling element ZPS

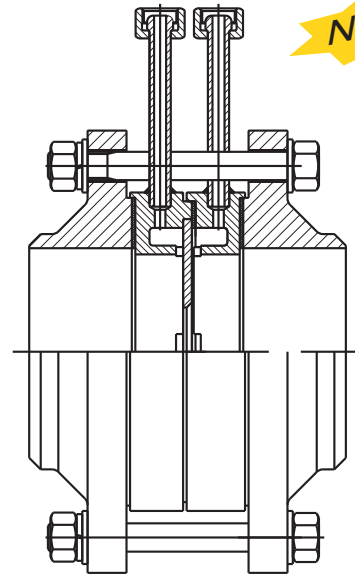
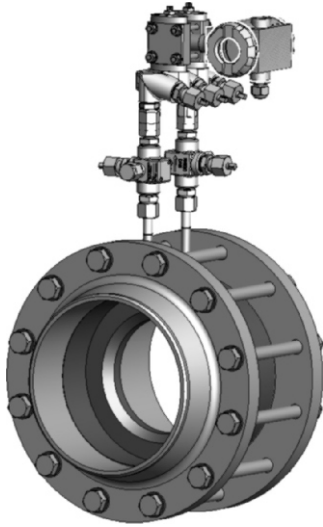

DN	angle spacing between measuring points Y							Steam PN 6, 10, 16, 25 40, 63, 100
	medium, gas							
	nominal pressure							
	PN6	PN10	PN16	PN25	PN40	PN63	PN100	
25+50	135°	135°	135°	135°	135°	135°	135°	0°, 90°, 180°
65	90°	90°	90°	90°	90°	90°	90°	
80								
100								
125	60°	60°	60°	60°	60°	60°	60°	
150								
200								
250								

Technical data:

- nominal pressure PN6+PN100
- size of flowmeter DN25+DN800
- material of flow element:
stainless steel 1.4301
- material of construction elements:
carbon steel
austenic steel
stainless steel
- temperature up to 500°C
- material certification
- calculation acc. to PN-EN ISO 5167, ISO/TR 15377

Application:

Measurement based on orifice plate with differential pressure transmitter is most widely used type of flow measurement. It can be used in flow measurement of steam, water and gases.

The biggest advantages of this solution are:

- high accuracy in wide measuring ranges
- applicable to measure flow of neutral and aggressive mediums
- easy calibration

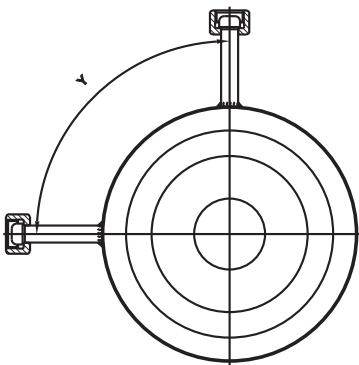

Ordering procedure:

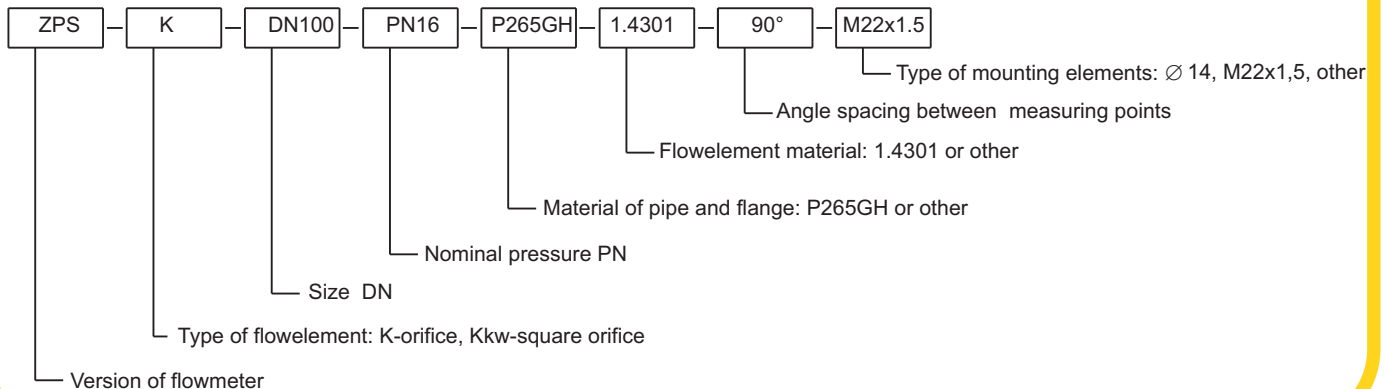

Venturi type flowmeter ZPS

NEW

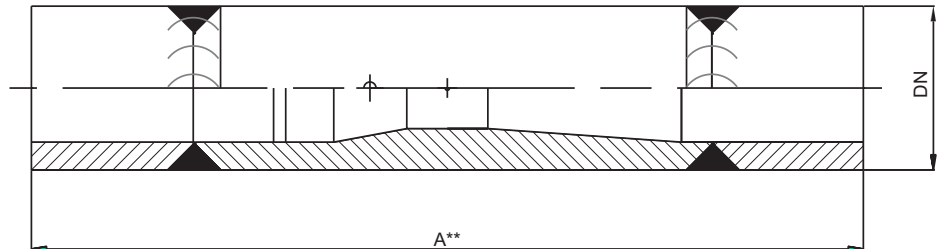
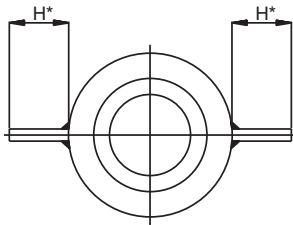

Technical data:

- nominal pressure PN6+PN160
- size of flowmeter DN65+DN800
- material of flow element (orifice, nozzle):
stainless steel 1.4301
- material of construction elements:
carbon steel
austenitic steel
stainless steel
- temperature up to 600°C
- material certification
- calculation acc. to PN-EN ISO 5167

Application:

Venturi flowmeter is used for flow measurement of liquid medium in close pipeline. An orifice plate installed in line creates a pressure drop. This difference of pressure is measured via impulse line by differential pressure transmitter. The relationship between the rate of flow and pressure drop is very well known and allows to easily convert measured pressure difference to flow value.

Flowmeters without correction are used for mediums with constant values of pressure and temperature.

For custody transfer measurement it's recommend to use differential pressure transmitters without SQRT characteristic and correction from changes of medium's pressure and temperature. This kind of measurement have to be calculated in dedicated flow counters.

Characteristic:

- high accuracy of measurement in wide range of flow
- resistant for aggressive media
- work in wide range of temp. and pressure

Ordering procedure:

