

Bourdon Tube Pressure Gauges Stainless Steel, Safety Pattern Version Model 232.30/233.30, without/with Liquid Filling

WIKA Data Sheet PM 02.04



Applications

- Increased safety requirements
- With liquid-filled case for applications with high dynamic pressure pulsations or vibrations
- For gaseous and liquid aggressive media that are not highly viscous or crystallising, also in aggressive ambience
- Process industries: chemical/petrochemical, power stations, mining, on- and offshore, environmental technology, machine building and plant construction

Special Features

- Safety pressure gauge with solid baffle wall designed in compliance with operational safety requirements of EN 837-1, BS 1780 and ASME B 40.1
- Excellent load-cycle stability and shock resistance
- All stainless steel construction
- Scale ranges up to 0 ... 1600 bar

Description

Design

EN 837-1

Nominal size in mm

63, 100, 160

Accuracy class

NS 63: 1,6

NS 100, 160: 1,0

Scale ranges

NS 63: 0 ... 1 to 0 ... 1000 bar

NS 100: 0 ... 0.6 to 0 ... 1000 bar

NS 160: 0 ... 0.6 to 0 ... 1600 bar

or all other equivalent vacuum or combined pressure and vacuum ranges



Bourdon Tube Pressure Gauge Model 232.30

Pressure limitation

NS 63:	Steady:	3/4 x full scale value
	Fluctuating:	2/3 x full scale value
	Short time:	full scale value
NS 100, 160:	Steady:	full scale value
	Fluctuating:	0.9 x full scale value
	Short time:	1.3 x full scale value

Operating temperature

Ambient:	-40 ... +60 °C without liquid filling
	-20 ... +60 °C gauges with glycerine filling
Medium:	+200 °C maximum without liquid filling
	+100 °C maximum with liquid filling

Temperature effect

When the temperature of the measuring system deviates from the reference temperature (+20 °C):
max. ±0.4 %/10 K of full scale value

Ingress protection

IP 65 per EN 60 529 / IEC 529
(gauges with back mount: IP 55)

Standard version

Process connection

Stainless steel 316L (NS 63: 1.4571),
 Lower mount (LM) or lower back mount (LBM) ¹⁾
 NS 63: G ¼ B (male), 14 mm flats
 NS 100, 160: G ½ B (male), 22 mm flats (NS 160 only
 lower mount)

Pressure element

Stainless steel 316L,
 < 100 bar: C-type
 ≥ 100 bar: helical type

Movement

Stainless steel

Dial

Aluminium, white, black lettering,
 NS 63 with pointer stop pin

Pointer

Aluminium, black

Case

Stainless steel, case with solid baffle wall and blow-out
 back, scale ranges ≤ 0 ... 16 bar (lower mount) with com-
 pensating valve to vent case

Window

Laminated safety glass (NS 63: Polycarbonate)

Bezel ring

Cam ring (bayonet type), stainless steel

Liquid filling (for Model 233.30)

Glycerine 99.7 %

1) Connector position back mount only
 for gauges NS 63 and 100 without liquid filling

Options

- Other process connection
- Assembly on diaphragm seals see product review DS
- Measuring system Monel (model 262.30)
- Measuring system stainless steel 1.4571
- Panel mounting flange, stainless steel or
 polished stainless steel
- Surface mounting lugs on case, stainless steel
- Ambient temperature -40 °C: silicone oil filling
- Ingress protection IP 66 / IP 67
- Pressure gauge with switch contacts, data sheet
 PV 22.02 and PV 22.03
- Pressure gauge with electrical output signal,
 see Model PGT23.100/160, data sheet PV 12.04
- Version per ATEX Ex II 2 GD c

Standard version

Lower mount (LM)

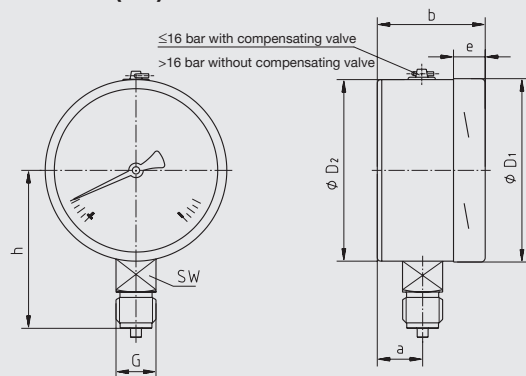

Lower back mount (LBM) ¹⁾

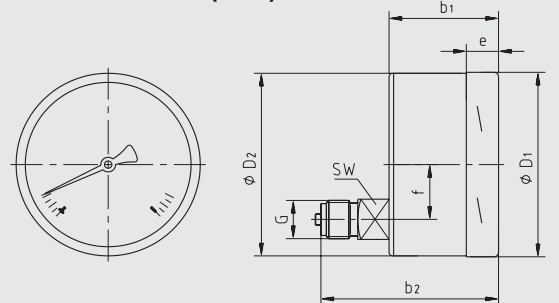

Dimensions in mm

NS	Dimensions in mm								Weight in kg				
	a	b	b ₁	b ₂	D ₁	D ₂	e	f	G	h ± 1	SW	Model 232.30	Model 233.30
63	17.5	42	42	61	63	63	14.5	18.5	G ¼ B	54	14	0.20	0.26
100	25	59.5	59.5	93	101	100	17	30	G ½ B	87	22	0.65	1.08
160	27 ²⁾	65 ³⁾	-	-	161	159	17.5	-	G ½ B	118	22	1.30	2.34

Process connection per EN 837-1 / 7.3

2) 41.5 mm with pressure ranges ≥ 100 bar

3) 79 mm with pressure ranges ≥ 100 bar

Ordering information

Model / Nominal size / Scale range / Connection size / Connection location / Options

Modifications may take place and materials specified may be replaced by others without prior notice.
 Specifications and dimensions given in this leaflet represent the state of engineering at the time of printing.



WIKAI Alexander Wiegand SE & Co. KG
 Alexander-Wiegand-Straße 30
 63911 Klingenberg/Germany
 Tel. (+49) 9372/132-0
 Fax (+49) 9372/132-406
 E-mail info@wika.de
 www.wika.de